

artisan®

CALL 1300 278 472

Australia's specialist food display equipment supplier



EXPO CHILLERS & FREEZERS



COLDMART



RIVIERA



afe

Artisan® Food Equipment Pty Ltd

Specialists in Self-contained Food Display Systems

1300 278 472 | sales@artisangroup.net.au | www.artisanfoodequipment.com.au

**Showrooms in Brisbane, Melbourne & Sydney.
Warehouses Australia-wide**

Call us
for your
PACKAGE DEAL

'RENT TO OWN'
 & OTHER FINANCE SOLUTIONS AVAILABLE
 CALL NOW FOR YOUR PACKAGE DEAL

CALL **1300 278 472**
 EMAIL sales@artisangroup.net.au

AUSTRALIA WIDE DELIVERY

SLIDING GLASS DOOR UPRIGHT CHILLERS



FEATURES ◦

- ✓ Tropicalised chillers
 - ✓ Extra wide clear vision self-closing sliding glass doors
 - ✓ Black or white interior & exterior
 - ✓ 6 tier display – 5 levels of adjustable wire shelves + base
- ### CUSTOM OPTIONS ◦
- ✓ Stainless steel interior & exterior
 - ✓ Bottom-mounted works
 - ✓ Remote works (with TX and Solenoid valve)

DOORS	LITRES NOMINAL	COLOUR	DIMENSIONS: WIDTH X HEIGHT X DEPTH	CHILLER MODEL
2	950L	WHITE	1260mm W x 2040mm H x 800mm D	M1112
2	950L	BLACK	1260mm W x 2040mm H x 800mm D	M1115
2	1400L	WHITE	1870mm W x 2040mm H x 800mm D	M1113
2	1400L	BLACK	1870mm W x 2040mm H x 800mm D	M1114



BOTTOM MOUNTED WORKS ◦

- ✓ Tropicalised chillers & freezers
 - ✓ White
 - ✓ 6 tier display – 5 levels of adjustable wire shelves + base
- ### CUSTOM OPTIONS ◦
- ✓ Remote works (with TX and Solenoid valve)

DOORS	LITRES	DIMENSIONS: WIDTH X HEIGHT X DEPTH	CHILLER -1°C to 4°C	FREEZER -18°C to -22°C
1	500L	640mm W x 2040mm H x 830mm D	M1121	M1321
2	1050L	1260mm W x 2040mm H x 750mm D	M1122	M1322
3	1500L	1870mm W x 2040mm H x 750mm D	M1123	M1323

BLACK DISPLAY CHILLERS & FREEZERS ◦



'ICE' SIGN OPTIONAL



DOORS	LITRES	DIMENSIONS: WIDTH X HEIGHT X DEPTH	CHILLER -1°C to 4°C	FREEZER -18°C to -22°C
1	500L	650mm W x 2040mm H x 830mm D	M1151	M1351
2	950L	1260mm W x 2040mm H x 750mm D	M1152	M1352
3	1400L	1870mm W x 2040mm H x 750mm D	M1153	M1353

Excellence in Commercial Refrigeration

CALL **1300 278 472**

UPRIGHT CHILLERS & FREEZERS



FEATURES ◦

- ✓ Tropicalised chillers & freezers
- ✓ 6 tier display – 5 levels of adjustable wire shelves + base

- ✓ Top mounted works
- ✓ Light box at top
- ✓ White

CUSTOM OPTIONS ◦

- ✓ Stainless steel interior & exterior
- ✓ Bottom-mounted works
- ✓ Remote works (with TX and Solenoid valves)
- ✓ Pass-through: doors to front & back
- ✓ View-through glass panel at front doors to view



Freezers now available with world-first Japanese Hitachi compressors

WHITE DISPLAY CHILLERS & FREEZERS

DOORS	LITRES NOMINAL	DIMENSIONS: WIDTH X HEIGHT X DEPTH	CHILLER -1°C to 4°C	FREEZER -18°C to -22°C
1	500L	650mm W x 2040mm H x 830mm D	M1101	M1301
2	500L/500L	1260mm W x 2040mm H x 750mm D	M1173	
2	950L	1260mm W x 2040mm H x 750mm D	M1102	M1302
3	1400L	1870mm W x 2040mm H x 750mm D	M1103T	M1303
4	1950L	2500mm W x 2040mm H x 860mm D	M1104	

STAINLESS STEEL DISPLAY CHILLERS & FREEZERS

DOORS	LITRES NOMINAL	DIMENSIONS: WIDTH X HEIGHT X DEPTH	CHILLER	FREEZER
1	550L	760mm W x 2040mm H x 830mm D	M1131	M1331
2	950L	1220mm W x 2040mm H x 730mm D	M1132	M1332
3	1400L	1820mm W x 2040mm H x 730mm D	M1133	M1333



HOST UNDER-COUNTER CHILLERS & FREEZERS



M2218



M2215



M2124
M2324



FEATURES

- ✓ Tropicalised chillers & freezers
- ✓ Stainless steel work-top on all models
- ✓ Solid doors or double-glazed glass doors
- ✓ Brilliant energy-saving LED lighting in glass door chillers
- ✓ 2 levels of adjustable wire shelves + base
- ✓ Forced draught refrigeration
- ✓ Automatic demisting of fascias
- ✓ Works easily accessed for maintenance
- ✓ Chiller: 1°C to 4°C
- ✓ Freezer: -16°C to -20°C

NEW RELEASE
Ask about our
MONACO BACK BAR
Slim-Line Display Chillers



M2115
M2312

Solid door units:	850mmH	(750mmH + castors)	x	750mmD
Glass door units:	850mmH	(750mmH + castors)	x	680mmD

DOORS	LENGTH	CHILLERS		FREEZER
		GLASS DOORS (LITRES)	SOLID DOORS (LITRES)	SOLID DOORS (LITRES)
2	1200mm	M2212 (200L)	M2112 (220L)	M2312 (220L)
2	1500mm	M2215 (300L)	M2115 (330L)	M2315 (330L)
3	1800mm	M2218 (400L)	M2118 (440L)	M2318 (440L)
3	2100mm	M2221 (500L)	M2121 (550L)	M2321 (550L)
4	2400mm	M2224 (600L)	M2124 (630L)	M2324 (630L)

CHILLER-FREEZER COMBOS



CHILLERS

FREEZER

M2418

M2421

850mmH (750mmH + castors) x 750mmD			
DOORS	LENGTH	SOLID DOORS	
1 FREEZER & 1 CHILLER	1500mm	M2415	
1 FREEZER & 2 CHILLER	1800mm	M2418	
	2100mm	M2421	

✓ Option to have fridge section with glass door



HOST UPRIGHT STAINLESS STEEL CHILLERS AND FREEZERS



M1521
M1621
M1751



M1522
M1622
M1752



M1523
M1623



M1512
M1612



M1511
M1611



M1513
M1613



FEATURES

- ✓ Tropicalised chillers & freezers
- ✓ Stainless steel doors: half-split-height & full height
- ✓ 4 levels of adjustable wire shelves + base
- ✓ Automatic demisting of fascias
- ✓ Rated for 43°C ambient working conditions

- ✓ Top mounted works
- ✓ Chiller: -1°C to 4°C
- ✓ Freezer: -18°C to -22°C

CUSTOM OPTIONS

- ✓ Remote works (with TX and Solenoid valves)
- ✓ Pass-through: doors to rear also



2040mm HIGH x 750mm DEEP					
BAY	DOORS	WIDTH	CHILLER (LITRES)	FREEZER (LITRES)	CHILLER & FREEZER COMBO
1	1 Full Height	760mm	M1511 (522L)	M1611 (522L)	
1	2 x 1/2	760mm	M1521 (522L)	M1621 (522L)	M1751
2	2 Full Height	1220mm	M1512 (930L)	M1612 (930L)	M1762
2	4 x 1/2	1220mm	M1522 (930L)	M1622 (930L)	
3	3 Full Height	1820mm	M1513 (1400L)	M1613 (1400L)	
3	6 x 1/2	1820mm	M1523 (1400L)	M1623 (1400L)	

Gourmet GASTRONORM CHILLERS & FREEZERS

FEATURES

- ✓ Tropicalised chillers & freezers
- ✓ Gastronorm compatible: 2-off x 1/1-size per shelf
- ✓ 5 levels of adjustable stainless steel wire shelves (530mm W x 650mm D) + base
- ✓ Automatic demisting of fascias
- ✓ Rated for 43°C ambient working conditions
- ✓ Top mounted works
- ✓ Chiller: -1°C to 4°C
- ✓ Freezer: -18°C to -22°C



DOORS	LITRES NOMINAL	DIMENSIONS: WIDTH X HEIGHT X DEPTH	CHILLER -1°C to 4°C	FREEZER -18°C to -22°C
1	600L	760mm W x 2040mm H x 860mm D	M1801	M1811
2	1200L	1360mm W x 2040mm H x 860mm D	M1802	M1812



BAKERS BUDDY UNDER-COUNTER CHILLERS & FREEZERS



NO MORE DOUBLE-HANDLING

Use your same standard 29" x 16" / 18" Racks & Shelves in your Bakers Buddy and your oven.

Adjustable 6 shelf/tray capacity per door

'RENT TO OWN' & OTHER FINANCE SOLUTIONS AVAILABLE CALL NOW FOR YOUR PACKAGE DEAL

UNDERBENCH 860mm H x 930mm D	CHILLER 0°C to 4°C	FREEZER -18°C to -22°C
2 DOOR 1800mm L	M2402	M2432
3 DOOR 2400mm L	M2403	M2433

* All prices exclude delivery & GST *Any offer is subject to our terms & conditions * All subject to change without notice



Lockable heavy duty wheels ensure easy maneuvering

Self Closing Doors with Open Dwell Action & "Easy Grip" Ergonomic Full Length Handles



Fully adjustable Shelf & Tray Slides*

*Wire shelves are not included – please order wire shelves separately



Electronic Controls & digital read-out, Fully Automatic, Automatic Condensate Disposal & Heavy-Duty Condenser

Available with optional 150mm H splash back

artisan®

www.artisanfoodequipment.com.au
Phone: 1300 278 472

artisan® CHILLERS & FREEZERS in 1, 2 & 3 door models that allow you to chill or freeze your product on the same standard baking racks & shelves that you use in your oven!



Bakers Buddy

DON'T WORK THROUGH EVERY NIGHT ... TALK TO ARTISAN AND YOU'LL RISE WITH THE SUN!



'RENT TO OWN' & OTHER FINANCE SOLUTIONS AVAILABLE CALL NOW FOR YOUR PACKAGE DEAL

Heated Door Frames

Adjustable 15 shelf/tray capacity per door

UPRIGHT 2040mm H x 930mm D	CHILLER 0°C to 4°C	FREEZER -18°C to -22°C	COMBO 1 door chiller 1 door freezer
1 DOOR 760 W	M1701	M1711	
2 DOOR 1220 W	M1702	M1712	M1722
3 DOOR 1820 W	M1703	M1713	

* All prices exclude delivery & GST *Any offer is subject to our terms & conditions * All subject to change without notice

NO MORE DOUBLE-HANDLING

Use your same standard 29" x 16" / 18" Racks & Shelves in your Bakers Buddy and your oven.

*Wire shelves are not included – please order wire shelves separately



CALL 1300 278 472
EMAIL sales@artisangroup.net.au

"THE BAKERS BUDDY TAKES THE BEAST OUT OF THE BAKERY" Gold Coast Baker

"THE BAKERS BUDDY ALLOWED US TO REDUCE OUR STAFF" Brisbane Baker

SAVE TIME ... SAVE LABOUR ... SAVE MONEY

'RENT TO OWN'
& OTHER FINANCE SOLUTIONS AVAILABLE
CALL NOW FOR YOUR PACKAGE DEAL

CALL **1300 278 472**

ARCTIC PLUS
DISPLAY CABINET

ARCTIC PLUS DISPLAY CABINET

FEATURES:

- 830mm display deck
- Curved profile
- Hinged-opening
- Tempered glass front
- Ventilated & cold base
- Self contained & auto
- Work bench
- Mobile on castors
- Electronic digital controller
- Full refrigerated storage underneath



Optional Bain-marie or hot plate cabinet available

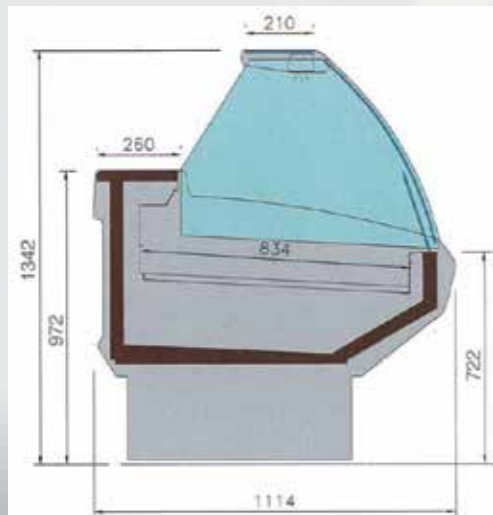

MODEL NUMBER	1342mm H x 1114mm D x Lengths
M5714	1330mm
M5717	1645mm
M5720	1955mm
M5726	2580mm
M5733	3205mm
M5739	3830mm

Internal and external corners available

Request our specialist brochure for this range
Call 1300 278 472

CALL **1300 278 472**

ARCTIC CLASSIC
DISPLAY CABINET

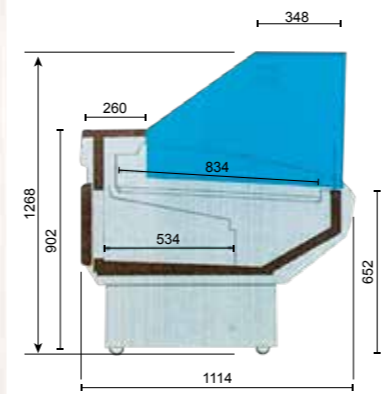

DELI ZIOSA, MLC, MARTIN PLACE

FEATURES

- New square glass profile
- Hinged-opening tempered glass front
- Ventilated and cold base
- Full refrigerated storage underneath
- Fully self-contained and automatic
- Auto defrost and self-evap system
- Mobile on castors
- Electronic digital controller
- Work bench
- Rear sliding acrylic doors
- Standard power point
- All factory pre-set for Aussie conditions ... ready to 'plug & play'

COMBINATIONS AVAILABLE: CALL US TODAY FOR A QUOTE FOR YOUR DESIGN



MODEL NUMBER	1250MM H x 1120MM D x LENGTHS
M5314	1330mm
M5317	1645mm
M5320	1955mm
M5326	2580mm
M5333	3205mm
M5339	3830mm

Internal and external corners available

'RENT TO OWN'
& OTHER FINANCE SOLUTIONS AVAILABLE
CALL NOW FOR YOUR PACKAGE DEAL



ARCTIC VOGUE DISPLAY CABINET

'RENT TO OWN'
 & OTHER FINANCE
 SOLUTIONS AVAILABLE
 CALL NOW FOR YOUR
 PACKAGE DEAL

FEATURES

- Mobile
- Glass top
- Work bench
- Ventilated refrigeration
- Auto defrost
- Electronic controls
- Glass shelf
- Grey tonings
- Light and compact
- Efficient/easy cleaning

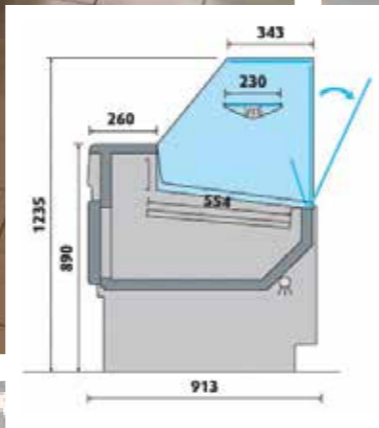

Model number	1305mm H x 913mm D x Lengths
M5410	1000mm
M5413	1300mm
M5415	1500mm
M5420	2000mm
M5425	2500mm



ARCTIC ICE DISPLAY CABINET

'RENT TO OWN'
 & OTHER FINANCE
 SOLUTIONS AVAILABLE
 CALL NOW FOR YOUR
 PACKAGE DEAL

FEATURES

- Cold plate style,
- Static twin-coil refrigeration
- Deck takes loose ice directly on display
- Tundish (drain) required
- Mobile

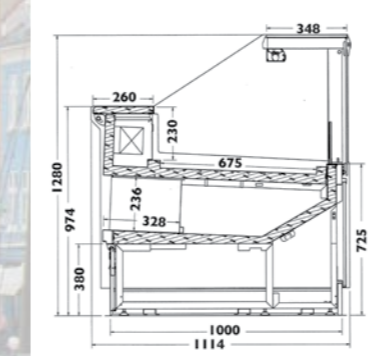

Perforated panels to allow display to drain.

Model number	1280mm H x 1114mm D x Lengths
M5601	1350mm
M5603	1975mm
M5604	2575mm

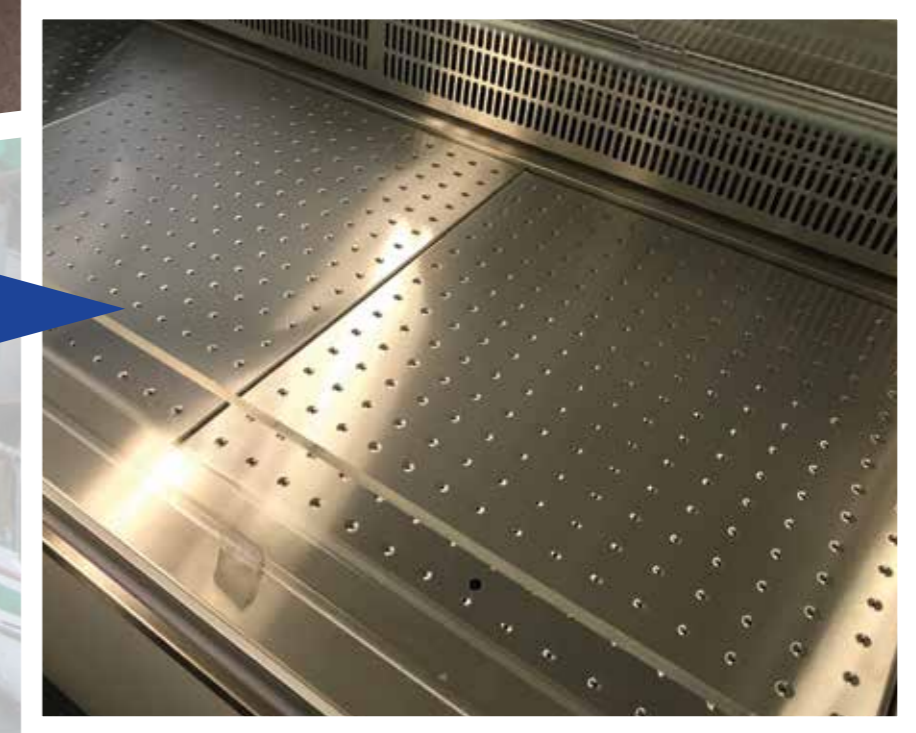

Request our specialist brochure for this range
Call 1300 278 472

CALL 1300 278 472

COLDMART DISPLAY FRIDGES

SUITS ALL PRODUCTS: MEAT, DAIRY, FLOWERS, FRUIT & VEGE'S, AND MUCH, MUCH MORE!



M4226MB



M4226MB



M4126ML

“Very pleased with the cabinet – doing a great job for us!”
Shane, Popular Tasmanian Butcher

“With your ‘Coldmart’ display our meat raffles have improved out of sight! Truly exceptional!”
GM of Sports Club, Central Coast

COLDMART CLASSIC OPEN-FRONT DISPLAY CHILLERS

sales@artisangroup.net.au | www.artisanfoodequipment.com.au

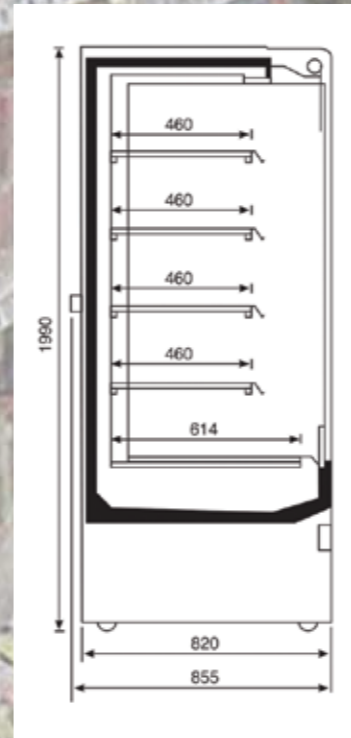

2000mm high x 855mm deep x lengths	5-Tier Display with White interior	5-Tier Display with Black interior
690mm L	M4107ML	M4207MB
870mm L	M4109ML	M4209MB
1310mm L	M4113ML	M4213MB
1510mm L	M4115ML	M4215MB
1940mm L	M4119ML	M4219MB
2560mm L	M4126ML	M4226MB



FEATURES:

- Interior in white or black
- 5-tier display: 4 levels height adjustable shelves + base
- Shelf product fences
- Brilliant LED lighting to every level
- Ticket edge for pricing labels
- Frost-free operation with auto defrost
- Electric element self-evaporative system
- Fully self-contained and automatic
- Night blind
- Mobile on heavy-duty castors
- Brilliant LED lighting to every level
- Electronic controller all factory pre-set ready to 'plug and play'

Request our specialist brochure for this range
Call 1300 278 472

CALL 1300 278 472

COLDMART DISPLAY FRIDGES

COLDMART SLIM-LINE OPEN-FRONT CHILLER

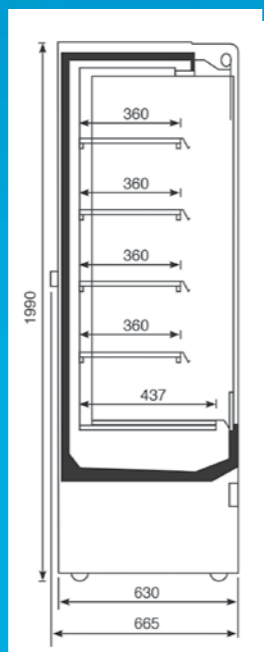

2000mm high x 665mm deep x lengths	5-Tier Display with White interior	Black interior
690mm L	M4607	M4707
870mm L	M4609	M4709
1310mm L	M4613	M4713
1510mm L	M4615	M4715
1940mm L	M4619	M4719

FEATURES:

- 5-tier display: 4 levels height adjustable shelves & base
- Shelf product fences
- Ticket edge for pricing labels
- Brilliant LED lighting to every level
- Frost-free operation with auto defrost
- Electric element self-evap system
- Fully self-contained and automatic
- Night blind
- Mobile on heavy-duty castors
- Electronic controller all factory pre-set ready to 'plug and play'
- White interior (black made to order)

COLDMART JUNIOR



CALL **1300 278 472**

EMAIL sales@artisangroup.net.au

VISIT www.artisanfoodequipment.com.au

FEATURES

- ✓ White interior
- ✓ 3-tier display: 2 levels height adjustable shelves + base
- ✓ Shelf product fences
- ✓ Ticket edge for pricing labels
- ✓ Brilliant LED lighting to every level
- ✓ Night blind
- ✓ Mobile on heavy-duty castors

'RENT TO OWN' & OTHER FINANCE SOLUTIONS AVAILABLE CALL NOW FOR YOUR PACKAGE DEAL

1420mm HIGH x 685mm DEEP x LENGTHS	3-TIER DISPLAY
705mm L	M4307M
890mm L	M4309M
1330mm L	M4313M
1530mm L	M4315M
1960mm L	M4319M

M4313M

CALL 1300 278 472

COLDMART GREEN



'RENT TO OWN' & OTHER FINANCE SOLUTIONS AVAILABLE CALL NOW FOR YOUR PACKAGE DEAL

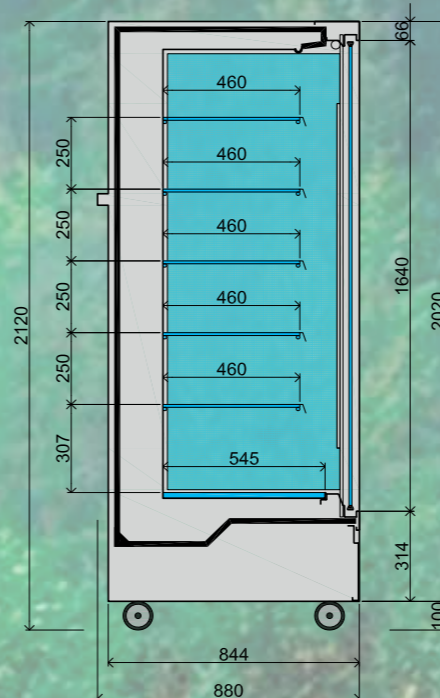

"Coldmart Green" ..efficiency meets pizzaz in retail display

- Double glazed self-closing doors with a dwell position for ease of loading
- 5 adjustable shelves plus the base
- Shelves can be sloping or straight
- LED light for every level
- Castors
- Plug in, self-contained
- Shelf ticket strip
- Digital controls
- Bump rails
- Runs the energy efficient R290 Emerson inverter compressor
- Inverter electronic fans

MODEL	M4551W	M4552W	M4553W	M4554W
COLOUR	WHITE	WHITE	WHITE	WHITE
MODEL	M4451B	M4552B	M4553B	M4554B
COLOUR	BLACK	BLACK	BLACK	BLACK
LENGTH WITH ENDS	1310mm	1935mm	2560mm	3750mm
NUMBER OF DOORS	2	3	4	6
DISPLAY AREA	1.98m2	2.97m2	3.96m2	5.94m2
POWER	10 amp/240 volt	15 amp/240 volt	15 amp/240 volt	20 amp/240 volt



TIFFANY DELICACY DISPLAY CASES



1000MM HIGH X 700MM DEEP X LENGTH	+3°C TO +8°C	PULL-OUT DISPLAY DRAWERS
1200mm Long	M3712	2
1500mm Long	M3715	3
1800mm Long	M3718	3

Features

- +3°C to +8°C
- Internal display height 250 mm
- LED lighting
- Stainless steel finish
- Mobile on castors
- Tropicalised with auto-demisting
- Electronic digital temperature display and control
- Fully self-contained
- Auto defrost and self-evap system
- Three lengths

MONACO BACK BAR Slim-Line Display Chillers

Features

- Black exterior
- Internal LED lights
- Automatic closing doors
- Digital controller
- Double-glazed doors
- Auto defrost
- Adjustable feet
- Can be built-in, except front
- Hinged and sliding door options
- Other options of colour & finish available



900MM HIGH X 520MM DEEP X LENGTHS	DOOR TYPE	LITRES NOMINAL	CHILLER 0°C TO 4°C
900mm L	Sliding – 2 doors	208L	M2253
1350mm L	Sliding – 2 doors	320L	M2255
600mm L	Hinging – 1 door	138L	M2262
900mm L	Hinging – 2 doors	208L	M2263
1350mm L	Hinging – 3 doors	320L	M2265

MONACO COUNTER TOP DISPLAY



FEATURES

- ✓ Matching hot and cold
- ✓ Fully self contained,
- ✓ sits on top of bench no cut outs required
- ✓ Internal LED lights
- ✓ Digital Control
- ✓ Double glazed glass and rear sliding doors

MODEL	TYPE	DIMENSIONS	CAPACITY LITERS
M3763	Heated to 75+ degrees	697mm W x 578mm D x 678mm H	130
M3764	Heated to 75+ degrees	875mm W x 578mm D x 678mm H	160
M3753	Cold 0 + degrees	697mm W x 578mm D x 678mm H	130
M3754	Cold 0 + degrees	875mm W x 578mm D x 678mm H	160

Finally... a deluxe bakery counter to suit your own standard racks. No more double-handling...use your same standard 29" x 16"/18" wire shelves in your Bakers Buddy, your oven...and your Le Chef.

The dream has come true for every baker and pastry cook!



LeChef Specifications

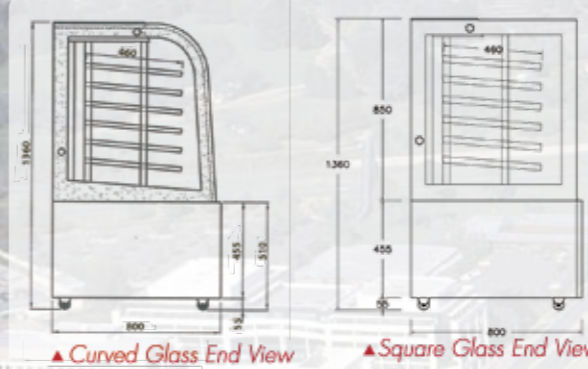

1360MM H X 800MM D X LENGTH	CAPACITY OF WIRE SHELVES (NOT INCLUDED)	GLASS FRONT	REFRIGERATED UP FROM 1°C	HEATED UP TO 75°C	AMBIENT DRY
1 - BAY 1060mm L	Up to 6 wire shelves 29" x 16"/18"	Curved	M3511	M3521	M3531
		Square	M3611	M3621	M3631
2 - BAY 1850mm L	Up to 12 wire shelves 29" x 16"/18"	Curved	M3512	M3522	M3532
		Square	M3612	M3622	M3632
3 - BAY 2640mm L	Up to 18 wire shelves 29" x 16"/18"	Curved	M3513	M3523	M3533
		Square	M3613	M3623	M3633



Request our specialist brochure for this range
Call 1300 278 472

CALL 1300 278 472

CUISINE Food Display Counters

1365mm High x 830mm Deep (1010mm deep when cutting board in place) x Length	1/1-Size Bays	Glass Front	Refrigerated	Food Pans	Refrigerated Storage Doors
900mm L	2	Curved	M2709	8 x 1/4	1
		Square	M2809	8 x 1/4	1
1200mm L	3	Curved	M2712	12 X 1/4	2
		Square	M2812	12 X 1/4	2
1500mm L	4	Curved	M2715	16 X 1/4	2
		Square	M2815	16 X 1/4	2
1800mm L	5	Curved	M2718	15 X 1/3	3
		Square	M2818	15 X 1/3	3
2150mm L	6	Curved	M2721	18 X 1/3	3
		Square	M2821	18 X 1/3	3
2450mm L	7	Curved	M2724	21 X 1/3	4
		Square	M2824	21 X 1/3	4



FEATURES

- ✓ Sliding doors to rear of display area
- ✓ Internal glass display shelf (dry)
- ✓ Interior display lighting
- ✓ Removable cutting board
- ✓ Refrigerated storage underneath
- ✓ Recessed ventilated air well
- ✓ Temperature range 2°C to 5°C
- ✓ Adjustable shelf to storage area with self-closing stainless steel doors



SORRENTO Food Prep Counters

FEATURES

- ✓ Raised ventilated air well with hinged lift-up stainless steel covers
- ✓ Suits standard Gastronorm pans
- ✓ 400 mm deep removable cutting board
- ✓ Refrigerated storage underneath
- ✓ Temperature range 2°C to 5°C
- ✓ Adjustable shelf to storage area with self-closing stainless steel doors

'RENT TO OWN' & OTHER FINANCE SOLUTIONS AVAILABLE CALL NOW FOR YOUR PACKAGE DEAL



1000mm HIGH x 740mm DEEP (1010mm when cutting board in place) x LENGTH	REFRIGERATED	1/3-SIZE FOOD PANS: 176mm W x 325mm D	HINGED LIFT-UP STAINLESS STEEL COVERS	CHILLER STORAGE DOORS
1200mm L	M2912	5 X 1/3	1	2
1500mm L	M2915	6 X 1/3	1	2
1800mm L	M2918	8 X 1/3	2	3
2100mm L	M2921	9 X 1/3	2	3
2400mm L	M2924	11 X 1/3	2	4

“The quality of your pizza counters is excellent, and they work very well!”
Antonio, South Sydney

Request our specialist brochure for this range
Call 1300 278 472

CALL 1300 278 472

RIVIERA DISPLAY CASES



FEATURES

- Refrigerated counter display: up from 1°C
- Heated Counter display: up to 80°C
- 4 levels of display, including 3 adjustable shelves
- Double-glazed front & top
- Double-glazed rear sliding doors
- Demisting of glass front, top & doors
- Lighting to every shelf
- High-grade stainless steel interior & exterior
- Electronic digital temperature display & controls
- Rated for 35°C ambient working conditions & 60% R.H.
- Auto defrost
- Mobile on hidden castors
- Ready to plug-in



1345MM H X 700MM D X LENGTH	GLASS FRONT	REFRIGERATED UP FROM 1°C	HEATED UP TO 75°C	AMBIENT DRY
900mm L	Curved	M3209	M3251	M3261
	Square	M3409	M3451	M3461
1200mm L	Curved	M3212	M3252	M3262
	Square	M3412	M3452	M3462
1500mm L	Curved	M3215	M3253	M3263
	Square	M3415	M3453	M3463
1800mm L	Curved	M3218	M3254	M3264
	Square	M3418	M3454	M3464
2400mm L	Curved	M3224	M3256	M3266
	Square	M3424	M3456	M3466



ALTERNATIVELY, WE CAN CUSTOM MANUFACTURE FOR THE LENGTH THAT SUITS YOU!

MONACO TOWER Display Cases



Features

- Chillers and Dual-temp Chiller/Freezers
- LED lighting
- Mobile on castors
- Double-glazed glass
- Electronic digital temperature display and control
- Fully self-contained
- Auto defrost and self-evap system

600mm W x 660mm D x 1810mm H	FUNCTION	SHELVES
M3801	Chiller: 4°C to 10°C	5 glass shelves: 450mm x 450mm
M3802	Chiller: 4°C to 10°C	6 rotating glass shelves: 430mm dia.
M3810	Dual-temp Chiller/Freezer: +5°C / -18°C	5 wire shelves: 450mm x 450mm

VENICE Scoopy Ice-cream Display Cabinet



FEATURES

- ✓ Danfoss compressor
- ✓ Glass canopy
- ✓ Takes 5 litre tubs
- ✓ Internal storage
- ✓ LED lighting
- ✓ Copper tubing
- ✓ On wheels
- ✓ Energy-efficient
- ✓ Thermostatic controller
- ✓ 2 sizes

MODEL NUMBER	660mm Deep x 1360mm High x	5 LITRE TUB CAPACITY
M2523	1310 mm	7 + 3
M2528	1810 mm	10 + 4

M2523, 7 + 3 tubs: internal 1180mm x 580mm



M2528, 10 + 4 tubs: internal 1680mm x 530mm

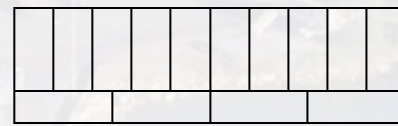

BIG BEAR Blast Freezer, -40°C

MODEL M1743

OPERATES TO MINUS 40°C
Rated for 40°C ambient working conditions

SIZE

- ✓ External 900 x 900 x 2030mm High
- ✓ Internal 740 x 460mm Wide

M1743 FEATURES

- ✓ Tropicalised
- ✓ Fitted with 15 sets of adjustable runners to take standard 29" x 16"/18" shelves (not incl.)
- ✓ Split doors (full height inside)
- ✓ Drain required
- ✓ Stainless Steel
- ✓ 20amp single phase 240 volt



artisan[®]

Australia's specialist food display equipment supplier

Request our specialist brochure for this range Call 1300 278 472

CALL 1300 278 472

PARIS DISPLAY CASES



'RENT TO OWN'
& OTHER FINANCE SOLUTIONS AVAILABLE
CALL NOW FOR YOUR PACKAGE DEAL

FEATURES

- Refrigerated counter display: up from 1°C
- Heated Counter display: up to 80°C
- 3 levels of display, including 2 adjustable shelves
- Double-glazed front & top
- Double-glazed rear sliding doors
- Demisting of glass front, top & doors
- Lighting to every shelf
- High-grade stainless steel interior & exterior
- Electronic digital temperature display & controls
- Rated for 35°C ambient working conditions & 60% R.H.
- Auto defrost
- Mobile on hidden castors
- Ready to plug-in

1200MM H X 700MM D X LENGTH	GLASS FRONT	REFRIGERATED UP FROM 1°C	HEATED UP TO 75°C	AMBIENT DRY
900mm L	Curved	M3309	M3351	M3361
	Square	M3109	M3151	M3161
1200mm L	Curved	M3312	M3352	M3362
	Square	M3112	M3152	M3162
1500mm L	Curved	M3315	M3353	M3363
	Square	M3115	M3153	M3163
1800mm L	Curved	M3318	M3354	M3364
	Square	M3118	M3154	M3164
2400mm L	Curved	M3324	M3356	M3366
	Square	M3124	M3156	M3166



ALTERNATIVELY, WE CAN CUSTOM MANUFACTURE FOR THE LENGTH THAT SUITS YOU!

MINIMART FREEZERS

STAINLESS STEEL WORK-TOP LID



M2513



M2618



LIGHT



MODEL NUMBER	SLIDING GLASS DISPLAY LIDS	HINGED STAINLESS STEEL WORKTOP	660mm DEEP X 905mm HIGH X LENGTH	LITRES	NUMBER OF BASKETS
M2508	✓		760mm L	300 Ltr	3
M2513	✓		1310mm L	420 Ltr	5
M2518	✓		1810mm L	610 Ltr	8
M2608		✓	760mm L	300 Ltr	3
M2613		✓	1310mm L	420 Ltr	5
M2618		✓	1810mm L	610 Ltr	8

FEATURES

- ✓ Danfoss Compressor
- ✓ All copper tubing
- ✓ Adjustable thermostat with indicator
- ✓ Mobile on castors
- ✓ Energy-efficient

SUPERMART ISLAND DISPLAY FREEZERS



M2586



M2587

FEATURES

- ✓ Efficient Static Refrigeration
- ✓ LED Light
- ✓ -18°C to -22°C
- ✓ Danfoss Compressor
- ✓ Full Basket with Dividers/Adj. Base (Max 530 D x 645 W)
- ✓ White with Grey Bump Rails
- ✓ On Wheels
- ✓ Rated for Ambient Working Conditions: 30°C & 55% R.H.
- ✓ Digital Controller
- ✓ Auto Condensate Disposal

MODEL NUMBER	990MM HIGH (INCL. CASTORS) X 854MM WIDE (875MM INCL. BUMP RAIL)	ENDS	LITRES	BAYS
M2586	1860mm LONG	CURVED	650 Ltr	4
M2587	2110mm LONG	SQUARE	780 Ltr	5
M2588	2510mm LONG	SQUARE	900 Ltr	6



FEATURES

- ✓ Dual temperature function allows operation as a fridge or a freezer with 'the-turn-of-a-key'
- ✓ Auto defrost and condensate disposal
- ✓ Digital thermostat
- ✓ Mobile on castors
- ✓ Night covers included
- ✓ 2 x LED horizontal lights

MODEL NUMBER	980MM HIGH (INCL. CASTORS) X 1070MM WIDE (INCL. BUMP RAIL)
M2595	1540mm LONG
M2598	2590mm LONG

SUPERMART DUAL DUAL-TEMP OPEN-TOP DISPLAYS

"The Dual-Temp works like a charm!
Paddy, Gourmet Melbourne Butcher"



ISLAND FOCUS SUPERMARKET CHEST FREEZER



MODEL NUMBER	COLOUR	LITRES - NOMINAL	DIMENSIONS
M2589	White	630	1950mm W x 850mm D x 800mm H
M2590	Black	630	1950mm W x 850mm D x 800mm H

- Island Freezers with Efficient Static Refrigeration
- Auto (Gas) Defrost
- Static Refrigeration
- L.E.D. Light
- -18C to -22C
- White with Grey Bump Rails
- Danfoss Compressor
- Rated for Amnient Working conditions: 30C & 55% R.H.
- Castors
- Digital Controller
- Auto Condensate Disposal

CRYSTAL MOUNTAIN ICE MACHINES



M6101
M6107



M6108
M6113

MODEL #	24hr Production (Ambience/Water)			BIN SIZE KG	240V 50HZ AMPS	SIZE W x D x H
	10°C/10°C	21°C/10°C	32°C/21°C			
M6101	22	17	15	9	2.5	460X460X640
M6102	60	48	40	22	2.5	530X600X770
M6103	90	72	60	40	3	610X650X910/1030
M6104	145	90	75	60	3.5	610X650X1100
M6105	180	115	95	136	4	560X800X1520
M6106	260	170	140	136	5.5	560X800X1710
M6107	300	240	210	180	6	760X820X1580
M6108	380	285	250	272	6.5	760X820X1780
M6109	480	385	320	272	7.5	760X820X1950
M6110	520	400	350	400	9	1000X820X1910
M6111	600	480	400	453	12	1220X820X1780
M6112	700	520	430	453	14	1220X820X1780
M6113	850	620	550	453	16	1220X820X1950

- ✓ STAINLESS STEEL CONSTRUCTION
- ✓ EASY CLEAN FILTER
- ✓ AIR COOLED
- ✓ C.E. APPROVED

MANY OPTIONS

- *Water Cooled
- *Cube Options: 28x28x22 / 22x25x22 / 25x22x12
- *LCD Screen option
- * Moon (Half-round) ice * Flake Ice

ABERDEEN™ DRY AGED MEAT

ABERDEEN™ DRY-AGING DISPLAY CHILLER

DOORS	DIMENSIONS: WIDTH x HEIGHT x DEPTH	CHILLER -1°C to 4°C
1	650mm W x 2040mm H x 800mm D	M1161
2	1260mm W x 2040mm H x 800mm D	M1162

Australian Design Registration No. 201612790

FEATURES

- All of the deluxe artisan® display chiller features; plus.....
- 40mm thick walls of beautiful multi-coral coloured HIMALAYAN SALT
- White LED lighting behind salt blocks in background
- Copper evaporator fins
- Full 304-grade stainless steel interior
- Signage
- Stainless steel evap tray
- OPTION: UV Light (Aust. Stds.)
- ✓ Anti-bacterial
- ✓ Reduces weight loss
- OPTION: Humidity Control

"Your Dry Aged Cabinet has been a huge success.
Boutique Butcher, Balmain, Sydney"



MASSIVE SAVINGS AVAILABLE NOW!

artisan[®]

CALL 1300 278 472

Australia's specialist food display equipment supplier



Artisan[®] Food Equipment Pty Ltd

Specialists in Self-contained Food Display Systems

Warehouses Australia-wide

1300 278 472 | sales@artisangroup.net.au | www.artisanfoodequipment.com.au